

7 kW

PowerPact™ Residential Standby Generator Air-Cooled Gas Engine

INCLUDES:

- True Power™ Electrical Technology
- Digital LED Controller
- Automatic Transfer Switch with Built-In Priority Load Center available with or without wiring whips
- Rugged Galvaneal Steel Rust Resistant Sound Attenuated Enclosure
- External Main Circuit Breaker and Control Panel Access
- Flexible Fuel Line Connector
- Composite Mounting Pads
- Natural Gas or LP Gas Operation
- 3 Year Limited Warranty
- UL 2200 Listed
- Capability to be installed within 18" (457 mm) of a building*

- Power Rating
- Model 006561-0 (Steel - Bisque) - 7 kW 60 Hz (Generator only)
 - Model 006518-0 (Steel - Bisque) - 7 kW 60 Hz (Generator with Pre-wired Switch)
 - Model 006519-0 (Steel - Bisque) - 7 kW 60 Hz (Generator with Non-Pre-wired Switch)



*Only if located away from doors, windows and fresh air intakes, and unless otherwise directed by local codes.

*Built in the USA using domestic and foreign parts

FEATURES

- **INNOVATIVE DESIGN & PROTOTYPE TESTING** are key components of GENERAC'S success in "IMPROVING POWER BY DESIGN." But it doesn't stop there. Total commitment to component testing, reliability testing, environmental testing, destruction and life testing, plus testing to applicable CSA, NEMA, EGSA, and other standards, allows you to choose GENERAC POWER SYSTEMS with the confidence that these systems will provide superior performance.
- **TEST CRITERIA:**
 - ✓ **PROTOTYPE TESTED**
 - ✓ **SYSTEM TORSIONAL TESTED**
 - ✓ **NEMA MG1-22 EVALUATION**
 - ✓ **MOTOR STARTING ABILITY**
- **POWERPACT™:** Offers an extreme value for those who desire automatic backup power at the most affordable price.
- **SINGLE SOURCE SERVICE RESPONSE** from Generac's dealer network provides parts and service know-how for the entire unit, from the engine to the smallest electronic component.
- **GENERAC TRANSFER SWITCHES.** Long life and reliability are synonymous with GENERAC POWER SYSTEMS. One reason for this confidence is that the GENERAC product line includes its own transfer systems and controls for total system compatibility.

PowerPact™ System - 7 kW

Engine

- Generac OHV engine A durable, reliable powertrain for maximum power output.
- Cast iron cylinder walls Rigid construction and added durability provide long engine life.
- Low oil level shutdown system Shutdown protection prevents catastrophic engine damage due to low oil.
- High temperature shutdown Prevents damage due to overheating.

Generator

- Revolving field Allows for a smaller, light weight unit that operates 25% more efficiently than a revolving armature generator.
- Skewed stator Produces a smooth output waveform for compatibility with sensitive electronic equipment, with less than 5% THD (total harmonic distortion).
- Displaced phase excitation Maximizes motor starting capability.
- Automatic voltage regulation Regulates the output voltage to ±5% prevents damaging voltage spikes.
- UL 2200 listed For your safety.

Transfer Switch (if equipped)

- Fully automatic Transfers your vital electrical loads to the energized source of power.
- Remote mounting Mounts near your existing distribution panel for simple, low cost installation.
- Flush mountable Can be installed between studs like a standard electrical panel.
- UL listed For your safety.

Digital Controls

- Multiple LED annunciation Provides specific system information without having to open the generator enclosure.
- Auto/Off/Manual buttons Select the operating mode.
- Utility voltage sensing Constantly monitors utility voltage, setpoints 65% dropout, 80% pick-up, of standard voltage.
- Utility interrupt delay Prevents nuisance start-ups of the engine, setpoint approximately 5 seconds.
- Engine warm-up Ensures engine is ready to assume the load, setpoint approximately 6 seconds.
- Engine cool-down Allows engine to cool prior to shutdown, setpoint approximately 1 minute.
- Seven day exerciser Operates engine to prevent oil seal drying and damage between power outages. (Adjustable to bi-weekly or monthly through the MobileLink™ system - sold separately.)
- Smart battery charger Maintains battery charge level to ensure starting.
- Main line circuit breaker Protects generator from overload.
- Multiple protection features Prevents additional damage from occurring within the generator if a fault condition arises.

Unit

- UL weather protective enclosure Sound attenuated enclosure ensures quiet operation and protection against mother nature. Three panels are removable for easy service and maintenance access.
- Enclosed critical grade muffler Quiet, critical grade muffler is mounted inside the unit to prevent injuries.
- Small, compact, attractive Makes for an easy, eye appealing installation, as close as 18" away from a building.*.

Installation System

- 1 ft (305 mm) flexible fuel line connector Absorbs any generator vibration when connected to rigid pipe.
- Composite mounting pads Eliminates the need to pour a concrete pad unless required by local municipalities.

PowerPact™ System - 7 kW

Generator

Model	006561-0, 006518-0 & 006519-0
Rated Maximum Continuous Power Capacity (LP)	7,000 Watts*
Rated Maximum Continuous Power Capacity (NG)	6,000 Watts*
Rated Voltage	240
Rated Maximum Continuous Load Current – 240 Volts	29.2 / 25
Main Line Circuit Breaker	30 Amp
Phase	1
Number of Rotor Poles	2
Rated AC Frequency	60Hz
Power Factor	1.0
Battery Requirement (not included)	Group U1, 12 Volts and 300 CCA Minimum
Unit Weight (lb/kg)	360/163.3
Dimensions (L x W x H) in./mm	36 x 27 x 25/915 x 676 x 640
Sound output in dB(A) at 23 ft (7 m) with generator operating at normal load**	69

Engine

Type of Engine	GENERAC OHV	
Number of Cylinders	1	
Displacement	420 cc	
Cylinder Block	Aluminum w/ Cast Iron Sleeve	
Valve Arrangement	Overhead Valve	
Ignition System	Solid-state w/ Magneto	
Governor System	Mechanical	
Starter	12 VDC	
Oil Capacity	Approx. 1.2 qt/1.1 L	
Operating rpm	3,600	
Fuel Consumption		
Natural Gas	ft ³ /hr (m ³ /hr)	
	1/2 Load	73 (2.07)
	Full Load	117 (3.31)
Liquid Propane	ft ³ /hr (gal/hr) [l/hr]	
	1/2 Load	26.2 (0.73) [2.75]
	Full Load	46.8 (1.3) [4.91]

Note: **Fuel pipe must be sized for full load.** Required fuel pressure to generator fuel inlet at all load ranges - 3.5-7" water column (6-13 mm mercury) for natural gas, 10-12" water column (19-22 mm mercury) for LP gas. For Btu content, multiply ft³/hr x 2500 (LP) or ft³/hr x 1000 (NG). For megajoule content, multiply m³/hr x 93.15 (LP) or m³/hr x 37.26 (NG).

Controls

LED Indicators	Simple user interface for ease of operation.	
Mode Switch:	Auto	Automatic Start on Utility failure. 7 day exerciser.
	Off	Stops unit. Power is removed. Control and charger still operate.
	Manual/Test (start)	Start with starter control, unit stays on. If utility fails, transfer to load takes place.
Engine Start Sequence	Cyclic cranking: Engine cranks a maximum of five times at factory set intervals and durations	
Engine Warm-up	6 sec	
Engine Cool-Down	1 min	
Starter Lock-out	Starter cannot re-engage until 5 sec after engine has stopped.	
2.5 Amp Smart Battery Charger	Standard	
Automatic Voltage Regulator	Standard	
Automatic Low Oil Level Shutdown	Standard	
Overspeed Shutdown	Standard	
Underspeed Shutdown	Standard	
High Temperature Shutdown	Standard	
Overcrank Protection	Standard	
Safety Fused	Standard	
Wiring Error Detection	Standard	
Battery Problem Warning	Standard	
Charger Problem Warning	Standard	
RPM Sensor Loss Shutdown	Standard	
Maintenance Indicators (Indicate Break-in and Regular Maintenance is due)	Standard	

**Sound levels are taken from the front of the generator. Sound levels taken from other sides of the generator may be higher depending on installation parameters. Rating definitions - Standby: Applicable for supplying emergency power for the duration of the utility power outage. No overload capability is available for this rating. (All ratings in accordance with BS5514, ISO3046 and DIN6271). * Maximum wattage and current are subject to and limited by such factors as fuel Btu/megajoule content, ambient temperature, altitude, engine power and condition, etc. Maximum power decreases about 3.5 percent for each 1,000 feet (304.8 meters) above sea level; and also will decrease about 1 percent for each 6 °C (10 °F) above 16 °C (60 °F).

PowerPact™ System - 7 kW

transfer switch

Transfer Switch Features

- Electrically operated, mechanically-held contacts for fast, positive connections.
- Rated for all classes of load, 100% equipment rated, both inductive and resistive.
- 2 pole, 240 VAC contactors.
- 60 millisecond transfer time.
- NEMA 1 (indoor rated) enclosure is standard.
- Flush mountable.

Model	006519-0	006518-0
No. of Poles	2	2
Current Rating (Amps)	50	50
Voltage	120/240 1Ø	120/240 1Ø
Utility Voltage Monitor (Fixed)*		
-Pick-up	80%	80%
-Dropout	65%	65%
Return to Utility*	approx. 15 sec.	approx. 15 sec.
Exerciser weekly for 12 minutes*	Standard	Standard
UL Listed	Standard	Standard
Total of Pre-wired Circuits	8	8
No. 15 A 120 V	5	5
No. 20 A 120 V	1	1
No. 20 A 240 V	-	-
No. 30 A 240 V	1	1
No. 40 A 240 V	-	-
No. 50 A 240 V	-	-
Circuit Breaker Protected		
Available RMS Symmetrical Fault Current @ 240 Volts	10,000	10,000
Weight (Pounds/Kilos)	20/9.1	25/11.3
Installation whips included	No	Yes

*Function of Controller, can be adjusted in Mobile Link if installed

Dimensions

Mechanical Dimensions					
	Height		Width		Depth
	H1	H2	W1	W2	D
in	11.5	14.8	11	14.4	4
mm	292	375	280	366	100

Wire Ranges	
Neutral Lug	Ground Lug
2/0 - #14	2/0 - #14

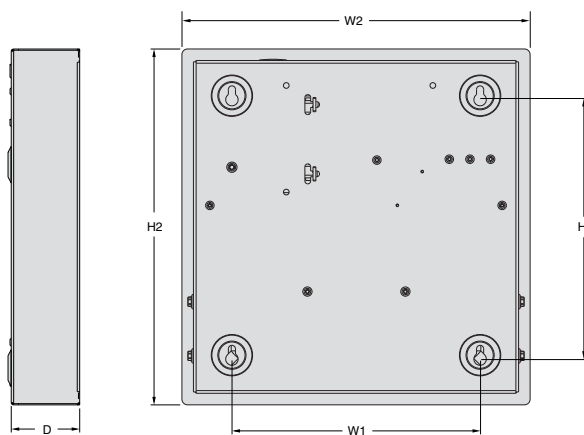

PowerPact™ System - 7 kW

Model #	Product	Description
006463-1	Mobile Link™	Generac's Mobile Link allows you to check the status of your generator from anywhere that you have access to an Internet connection from a PC or with any smart device. You will even be notified when a change in the generator's status occurs via e-mail or text message.
006664-0	Wireless Remote Monitor	Completely wireless and battery powered, Generac's wireless remote monitor provides you with instant status information without ever leaving the house. Not compatible with CorePower or EcoGen systems.
006808-0	Cold Weather Kit	The cold weather kit is required for PowerPact units installed in regions where the temperature regularly falls below 32 °F (0 °C).
006806-0	Scheduled Maintenance Kit	Generac's scheduled maintenance kits provide all the hardware necessary to perform complete routine maintenance on a Generac automatic standby generator.
005703-0	Paint Kit	If the generator enclosure is scratched or damaged, it is important to touch-up the paint to protect from future corrosion. The paint kit includes the necessary paint to properly maintain or touch-up a generator enclosure.

dimensions & UPC

Dimensions shown are approximate. Refer to installation manual for exact dimensions. DO NOT USE THESE DIMENSIONS FOR INSTALLATION PURPOSES.

